

Regulatory Approach to the Use of Probabilistic Fracture Mechanics at Nuclear Power Plants in the United States

Remarks by

David Alley

Chief, Piping and Head
Penetration Branch

David Rudland

Senior Level Advisor for
Materials

Office of Nuclear Reactor Regulations

2nd International Seminar on Probabilistic
Methodologies for Nuclear Applications, October 25-
26, 2017, Ottawa, Ontario, Canada

Deterministic Regulations

- Initial NRC Regulations use prescriptive, deterministic requirements

93^d CONGRESS } HOUSE OF REPRESENTATIVES { REPORT
2^d Session } No. 93-1445

ENERGY REORGANIZATION ACT OF 1974

OCTOBER 8, 1974.—Ordered to be printed

Mr. HOLIFIELD, from the committee of conference,
submitted the following

CONFERENCE REPORT

[To accompany H.R. 11510]

TITLE II—NUCLEAR REGULATORY COMMISSION

ESTABLISHMENT AND TRANSFERS

Sec. 201. (a) (1) There is established an independent regulatory commission to be known as the Nuclear Regulatory Commission which shall be composed of five members, each of whom shall be a citizen of the United States. The President shall designate one member of the Commission as Chairman thereof to serve as such during the pleasure of the President. The Chairman may from time to time designate any other member of the Commission as Acting Chairman to act in the place and stead of the Chairman during his absence. The Chairman (or the Acting Chairman in the absence of the Chairman) shall preside at all meetings of the Commission and a quorum for the transaction of business shall consist of at least three members present. Each member of the Commission, including the Chairman, shall have equal responsibility and authority in all decisions and actions of the Commission, shall have full access to all information relating to the performance of his duties or responsibilities, and shall have one vote. Action of the Commission shall be determined by a majority vote of the members present. The Chairman (or Acting Chairman in the absence of the Chairman) shall be the official spokesman of the Commission in its relations with the Congress, Government agencies, persons, or the public, and, on behalf of the Commission, shall see to the faithful execution of the policies and decisions of the Commission, and shall report thereon to the Commission from time to time or as the Commission may direct. The Commission shall have an official seal which shall be judicially noticed.

(2) The Chairman of the Commission shall be the principal executive officer of the Commission, and he shall exercise all of the executive and administrative functions of the Commission, including functions of the Commission with respect to (A) the appointment and supervision of personnel employed under the Commission (other than personnel employed regularly and full time in the immediate offices of commissioners other than the Chairman and except as otherwise provided in this Act), (B) the distribution of business among personnel appointed and supervised by the Chairman and among administrative units of the Commission, and (C) the use and expenditure of funds.

(3) In carrying out any of his functions under the provisions of this subsection the Chairman shall be governed by general policies of the Commission and by such regulatory decisions, findings, and determinations as the Commission may by law be authorized to make.

(b) (1) Members of the Commission shall be appointed by the President, by and with the advice and consent of the Senate.

Probabilistic Policy

- NRC is adopting risk informed approach to regulation
- Long process
 - Technical hurdles
 - Personnel hurdles

60 FR 42622
Published 8/16/95
Effective 8/16/95

**Use of Probabilistic Risk Assessment
Methods in Nuclear Regulatory
Activities; Final Policy Statement**

AGENCY: Nuclear Regulatory
Commission.

ACTION: Final policy statement.

SUMMARY: This statement presents the policy that the Nuclear Regulatory Commission (NRC) will follow in the use of probabilistic risk assessment (PRA) methods in nuclear regulatory matters. The Commission believes that an overall policy on the use of PRA methods in nuclear regulatory activities should be established so that the many potential applications of PRA can be

Objective

- Objective is integrated decision making
- Key is risk informed not risk based
- Problem is use for issues with small CDF impact

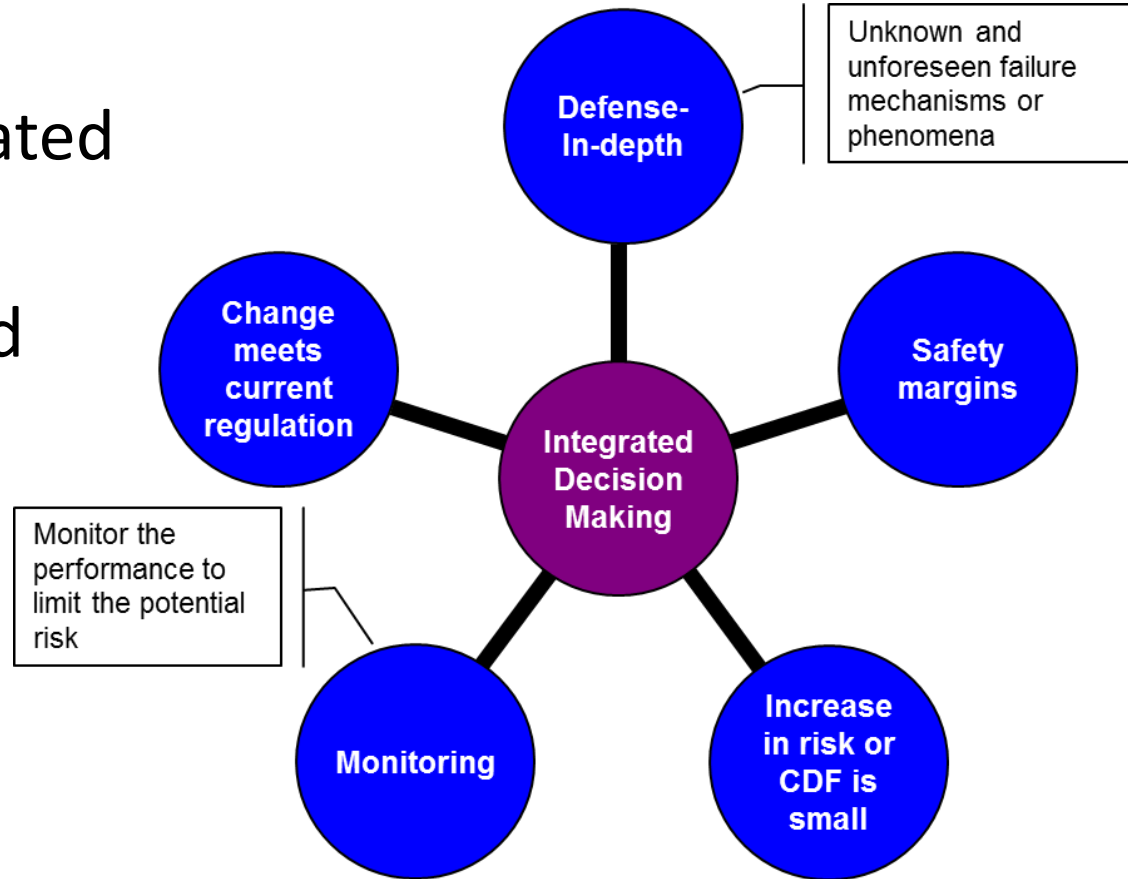

Initial Focus

- Probabilistic Risk Assessment (PRA)



U.S. NUCLEAR REGULATORY COMMISSION

May 2011
Revision 2

REGULATORY GUIDE

OFFICE OF NUCLEAR REGULATORY RESEARCH

REGULATORY GUIDE 1.174

(Draft was issued as DG-1226, dated August 2009)

AN APPROACH FOR USING PROBABILISTIC RISK ASSESSMENT IN RISK-INFORMED DECISIONS ON PLANT- SPECIFIC CHANGES TO THE LICENSING BASIS

Addresses CDF, LERF

- RG 1.174 – based on changes to CDF and LERF
- Acceptance is based on change in risk

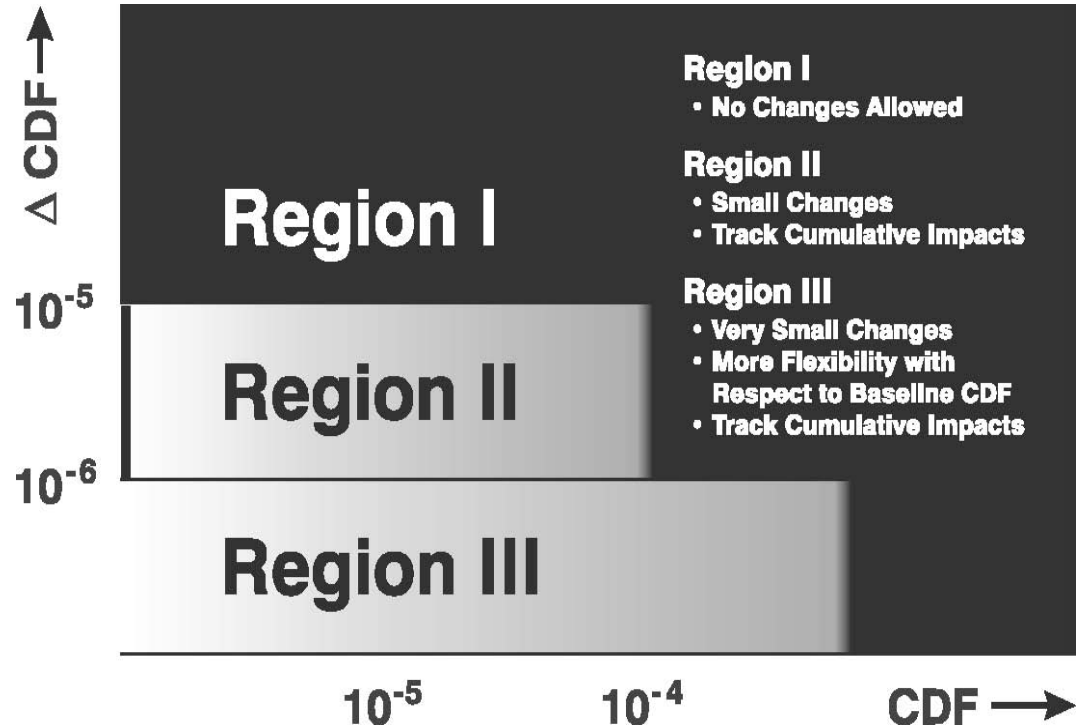

Wider Use of Risk Needed

- No change in licensing basis
- Small change in CDF
- Precursor to PRA
- Traditionally deterministic

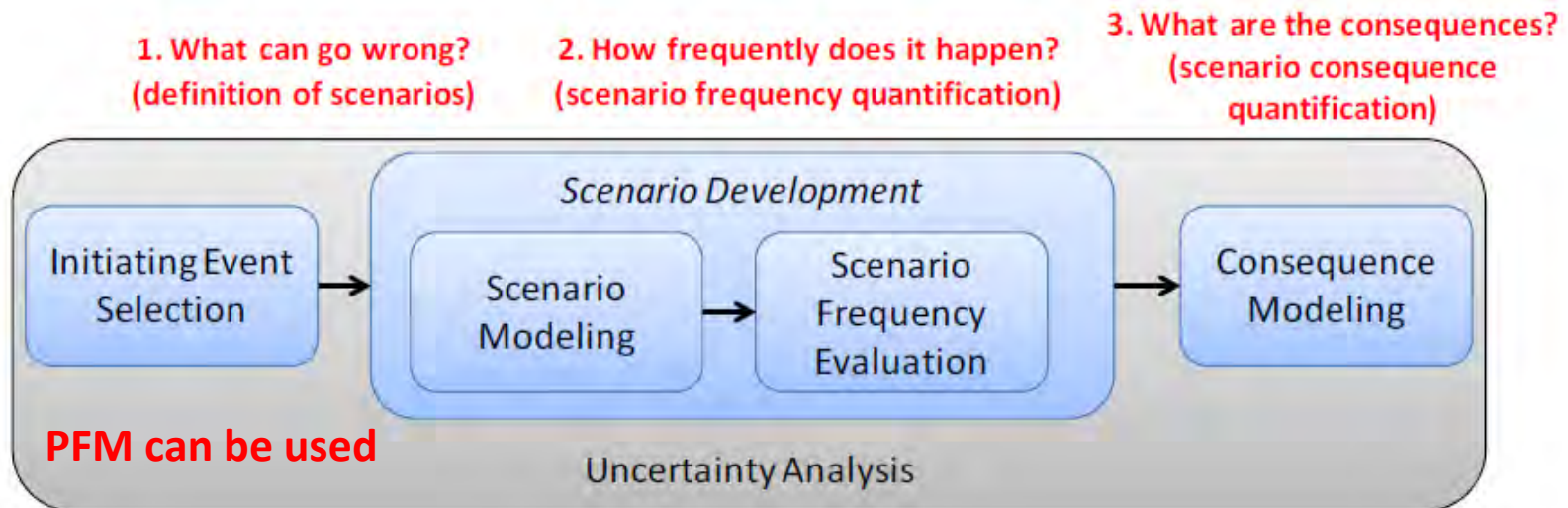

Some Successes

Submittals

- Piping
- Vessel welds
- Flywheel

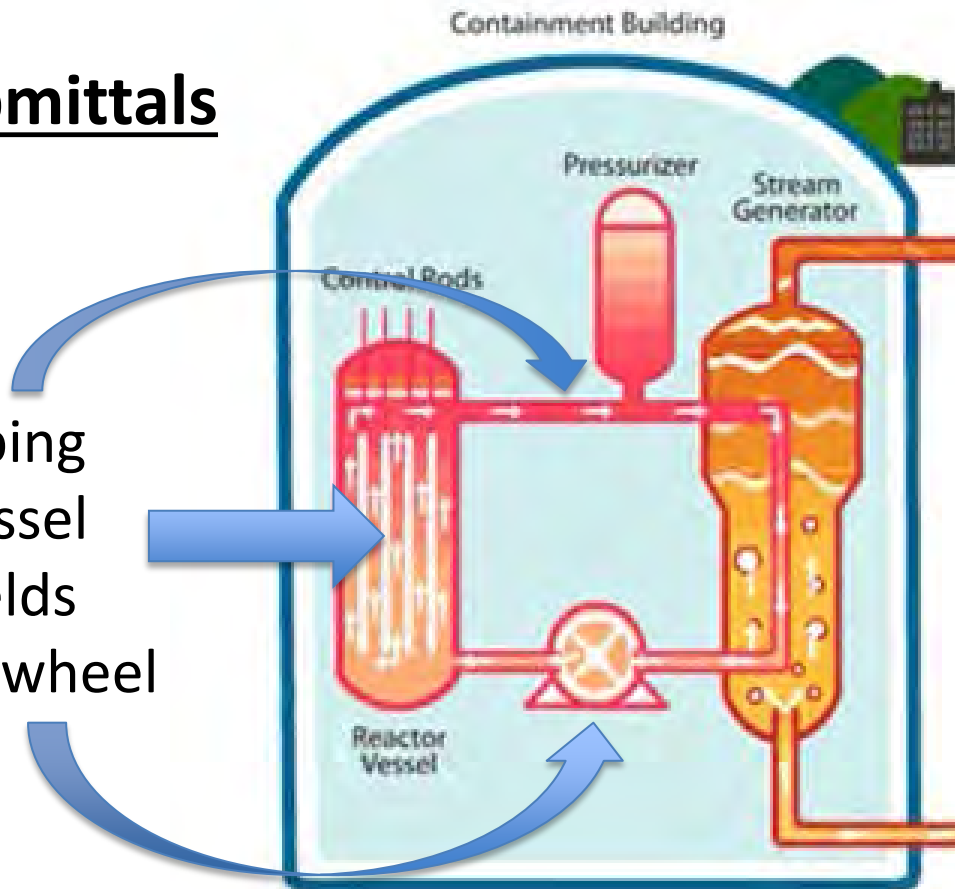

NRC Use

- 10CFR50.61, 61a
- BTP5-3
- Confirmatory calculations
- Revised inspection programs

Vessel Integrity – FAVOR, VIPER

- Industry developed VIPER/VIPERNOZ for inspection reduction for vessel weld and nozzle-to-shell welds
- FAVOR – originally developed for 10 CFR 50.61 RT_{PTS} screening criteria. Used in 10CFR50.61a development
 - Formal V&V done on FAVOR v02.4
 - ORNL internal quality assurance process
 - Extensive reviews of PTS (50.61a) results
 - Update V&V underway
- Staff used experience with FAVOR, benchmarking with FAVOR and review of VIPER technical basis in safety evaluation for BWRVIP-05

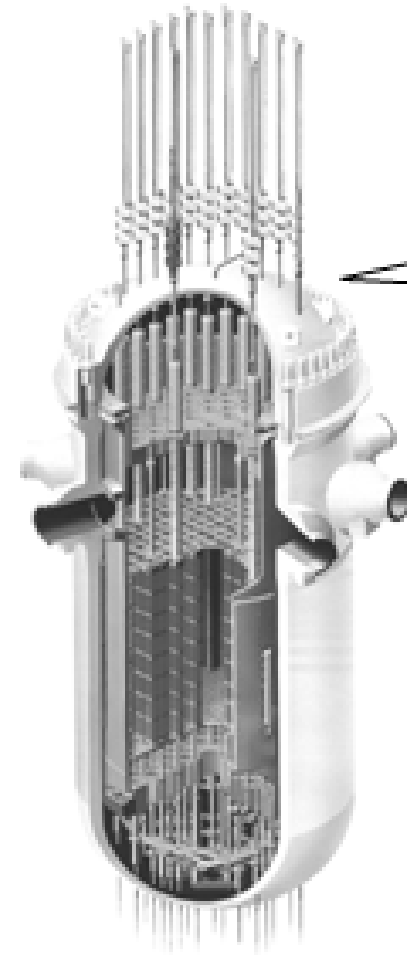

Risk-informed Piping Inspections

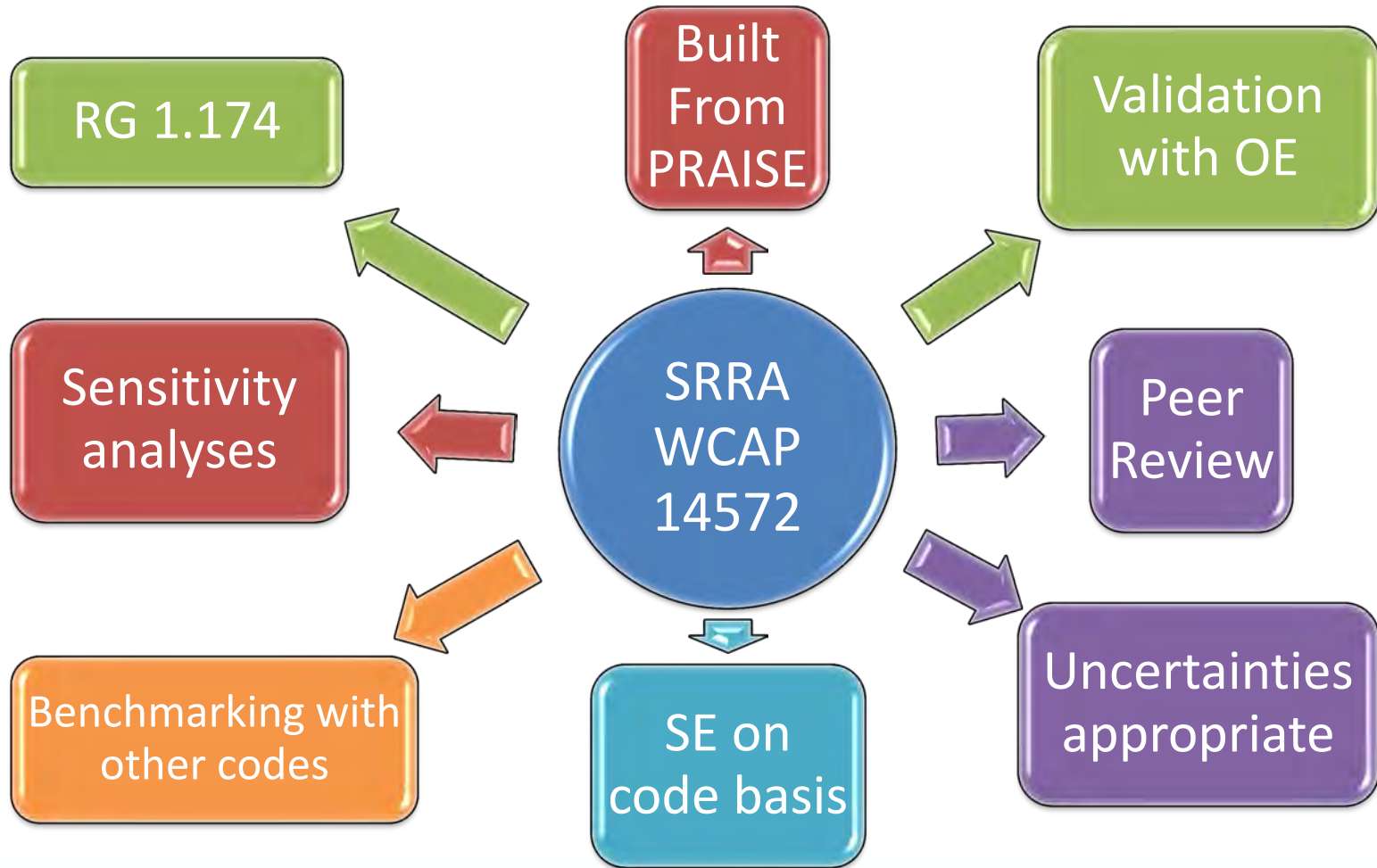

Bases for Success

- Computer code bases were technically adequate (V&V)
- RG1.174 process was followed or probabilities were very small
- In many cases, deterministic and probabilistic analyses were used
- Sensitivity/uncertainty analyses used to demonstrate impact of important variables

Uncertainty & Sensitivity Analyses

- What drives the problem?
- Inputs and models defensible?
- How to represent output?

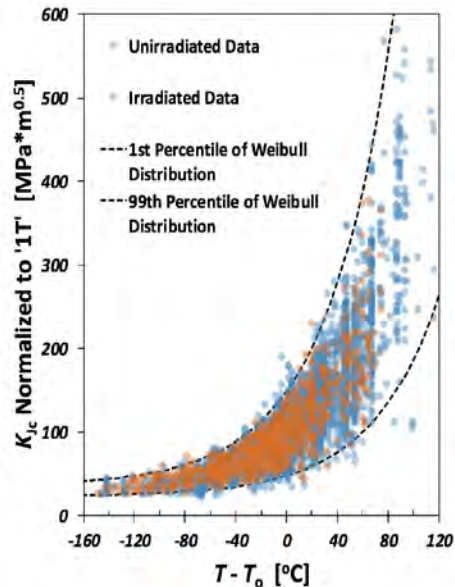

Data are important!

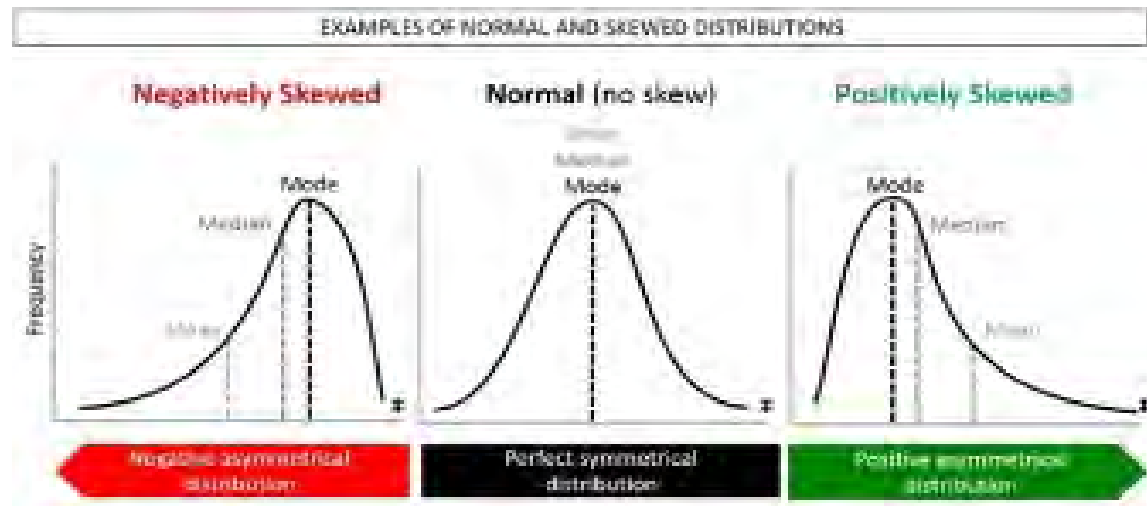

Mean, mode, median, other?

PFM Challenges in Piping and Vessels

- Incomplete uncertainty characterization
- Code and basis not submitted for review
- Incomplete code technical basis
- Incomplete V&V
- Ignored tenants of risk-informed decision making
- Acceptance criteria?



Path Forward

- Develop PFM best practices
Regulatory Guide
- Determine how to fit PFM into existing probabilistic approaches
 - Events not modeled in PRA
 - Events with minimal CDF impact
 - Retain risk informed

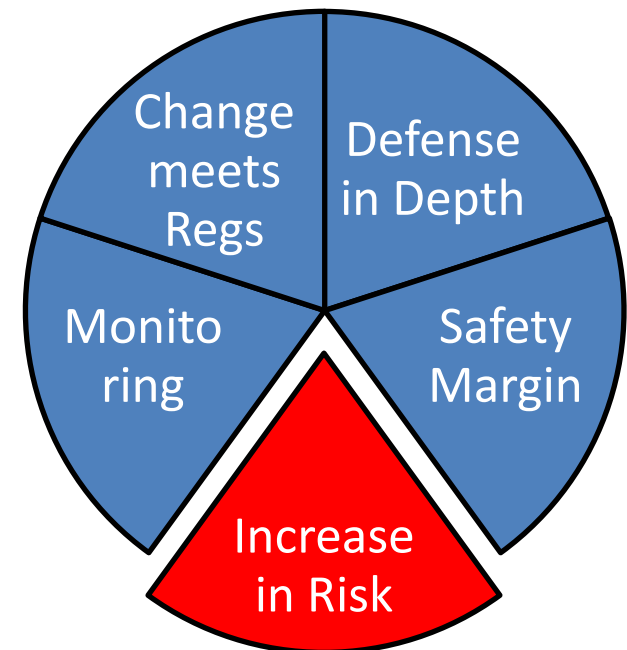

Summary

- NRC is committed to risk-informed decision making
- Process for risk-informed decision making in license basis changes is well documented
- There have been past successes but many challenges in using PFM in licensing actions
- Guidance is needed for how to conduct PFM
- Gap exists in guidance for events not directly modelled in PRA